



AUSSIE CHUTES HIRE & SALES

30/218 Wisemans Ferry Rd Somersby NSW 2250

Freecall 1800 023 523 Mobile 0417 210 415

ABN 40 424 920 966

www.aussiechutes.com.au

PRODUCT DATA SHEET

Large Side Entry Hopper

PRIMARY APPLICATIONS

For use when multiple entry points are required along the drop of the chute.

Most suited for multi-level work sites.

Types of debris include:

- tiles
- bricks
- gyprock
- waste to be loaded with buckets / shovel / by hand

FEATURES/BENEFITS

- Large Diameter
- Highly durable
- Lightweight
- Connected by chains
- Lockable door with "Danger: Chute Closed" sign
- Top lid & removable liners available
- 4 point scaffold attachment
- 30° hopper angle
- Side loading
- Stackable



TECHNICAL INFORMATION

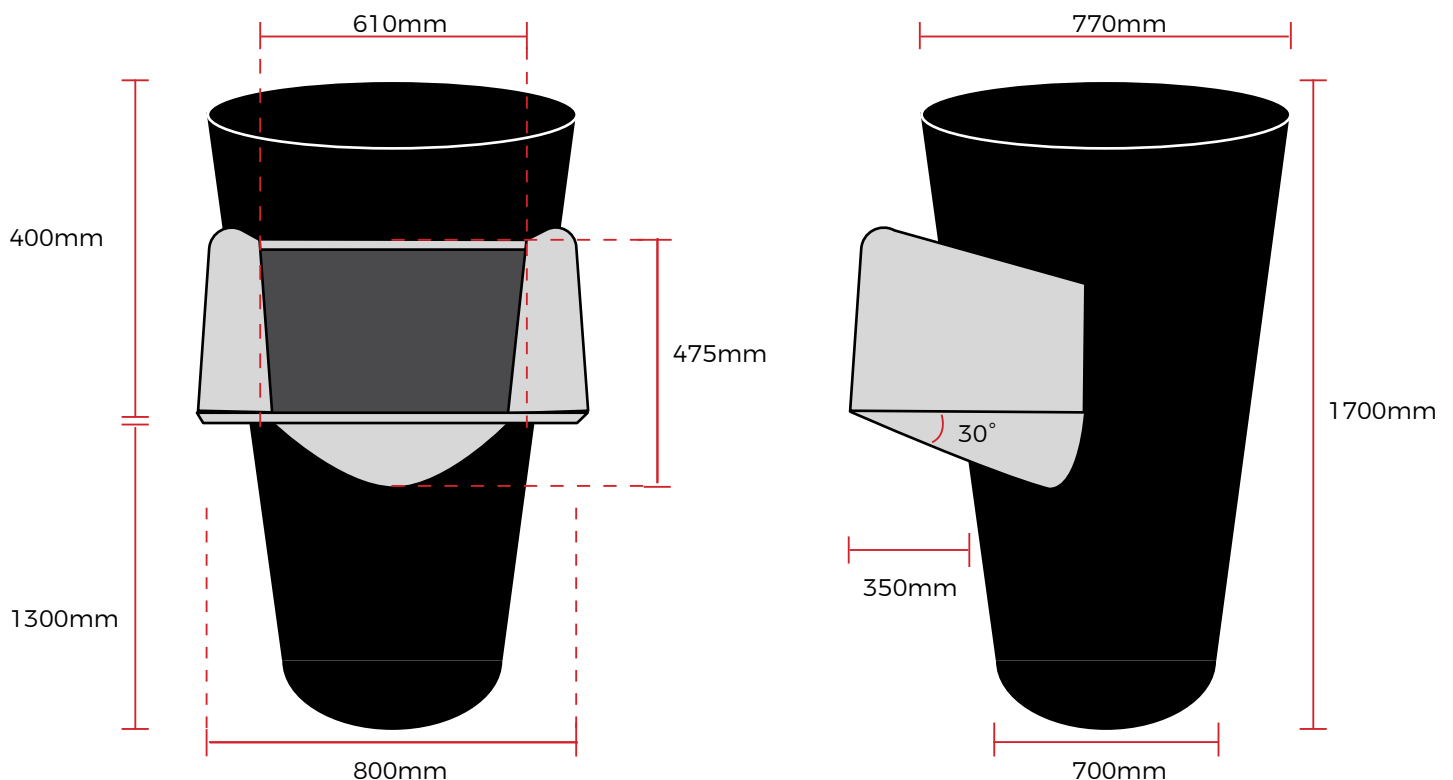

EXAMPLE INSTALLATIONS

Mounted on Scaffold

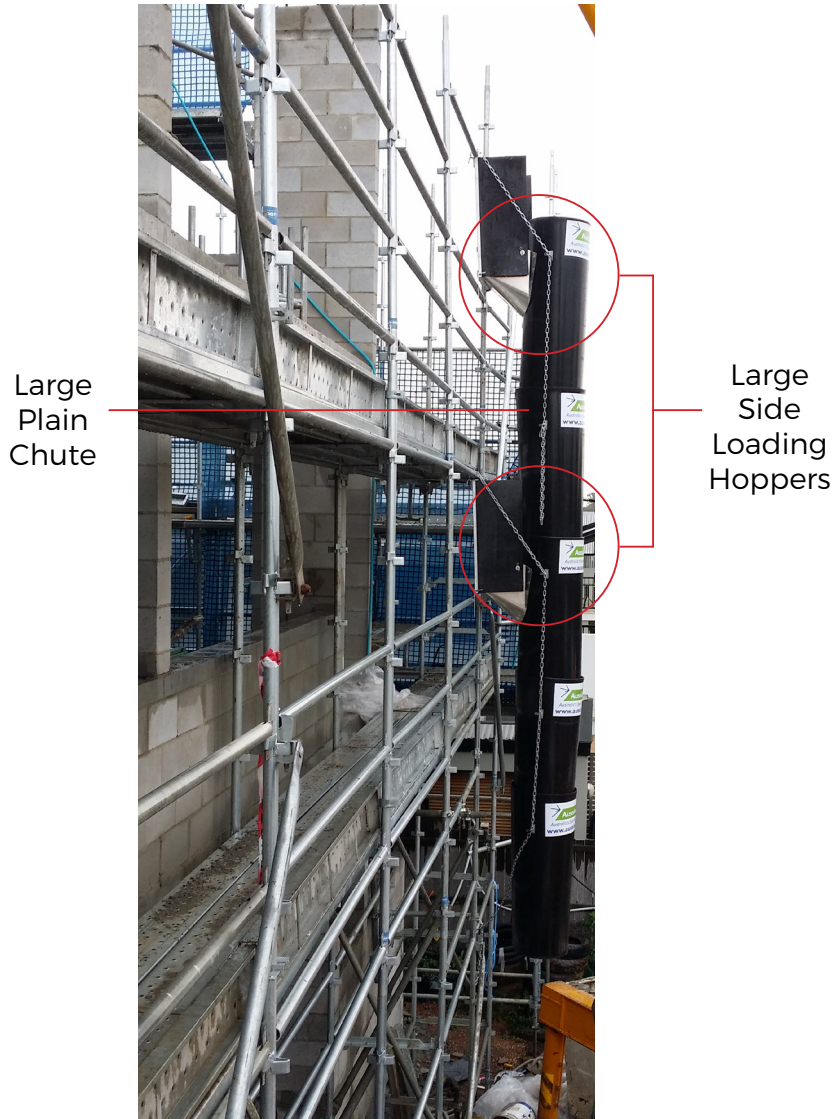

Mounted on Slab

